

## Suction cup F40-2 Silicone FCM

Item number: F40-2.21

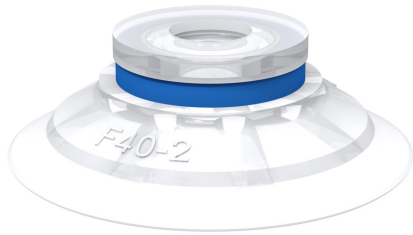

- The silicone material complies with FDA 21 CFR 177.2600 & EU 1935/2004.
- Suitable for flat objects.
- Good stability and little inherent movement.
- Recommended when the lifting force is parallel to the surface of the object.
- Cleats prevent thin, sensitive objects from being deformed and gives extra friction when the lifting force is parallel.

### Technical data

Description	Unit	Value
Suction cup shape	-	Flat
Application	-	Food contact materials (FDA & EU), non-detectable
Suction cup design	-	Round
Characteristics	-	Food contact materials (FDA & EU), non-detectable
Material	-	Silicone (SIL)
Weight, min.	oz	0.19
Suction cup model	-	F
Volume	in <sup>3</sup>	0.29
Height	in	0.51
Outer diameter, min.	in	1.65
Fitting size	-	None
Fitting option	-	None
Fitting style	-	None
Fitting type	-	None
Suction cup model	-	F40-2
Movement, vertical max.	in	0.071
Curve radius, min.	in	2.047

### Performance - Lifting forces

F40-2	Vertical (lb)	Parallel (lb)
5.91 -inHg	4.50	3.37
17.72 -inHg	8.99	5.62
26.58 -inHg	11.24	6.74

Material	
Name	Silicone (SIL FDA) 50° Shore
Color	Transparent
Temperature, min.   °F	-40.0
Temperature max.   °F	392.0
Hardness   °Shore A	50

#### Material resistance

Alcohol	Good
Concentrated acids	Poor
Ethanol	n/a
Hydrolysis	Fair
Methanol	n/a
Oil	Poor
Oxidation	Excellent
Gasoline	Poor
Wear resistance	Good
Weather and ozone	Excellent

#### Dimensional drawings

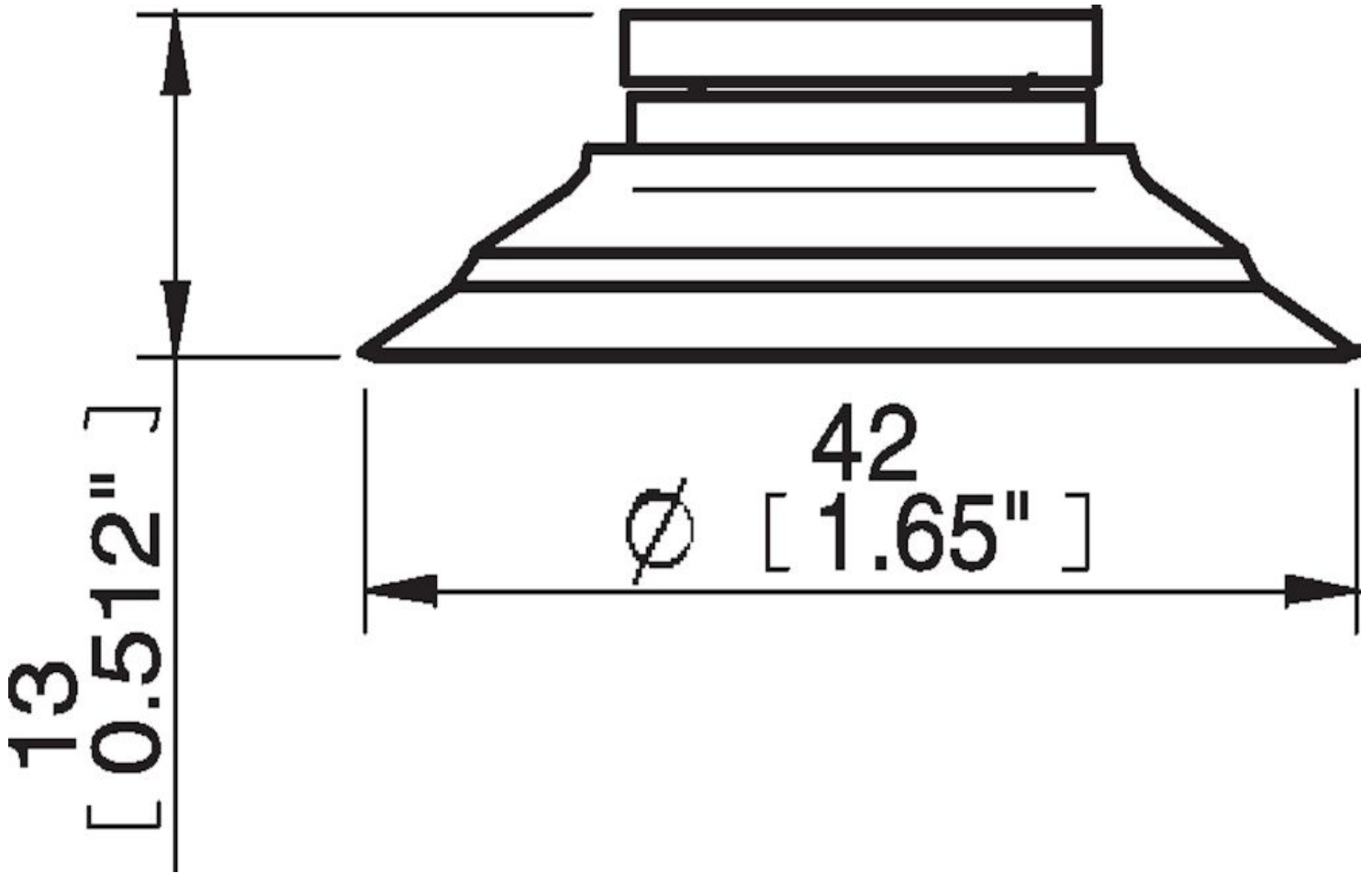

#### Values specified in this data sheet are tested at (unless otherwise stated):

- Room temperature (20°C [68°F] ± 3°C [5.5°F]).
- Standard atmosphere (101.3 [29.9 inHg] ± 1.0 kPa [0.3 inHg]).
- Relative humidity 20-70%.
- Compressed air quality, DIN ISO 8573-1 class 4.

## Accessories

04AG | Fitting 1/8" NPSF female, 30–40, with mesh filter

04AB | Fitting G1/4" male, 30–40, with mesh filter

04AC | Fitting 1/4" NPT male, with mesh filter