

Suction cup F30-2 Silicone FCM

Item number: F30-2.21

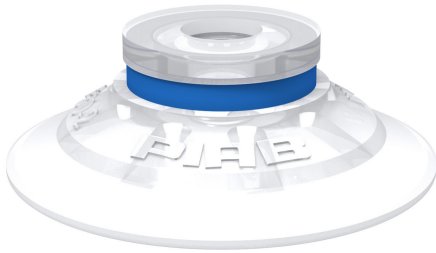

- The silicone material complies with FDA 21 CFR 177.2600 & EU 1935/2004.
- Suitable for flat objects.
- Good stability and little inherent movement.
- Recommended when the lifting force is parallel to the surface of the object.
- Cleats prevent thin, sensitive objects from being deformed and gives extra friction when the lifting force is parallel.

Technical data

Description	Unit	Value
Suction cup shape	-	Flat
Application	-	Food contact materials (FDA & EU), non-detectable
Suction cup design	-	Round
Characteristics	-	Food contact materials (FDA & EU), non-detectable
Material	-	Silicone (SIL)
Weight, min.	oz	0.078
Suction cup model	-	F
Volume	in ³	0.12
Height	in	0.41
Outer diameter, min.	in	1.26
Outer diameter, actuated	in	1.28
Fitting size	-	None
Fitting option	-	None
Fitting style	-	None
Fitting type	-	None
Suction cup model	-	F30-2
Movement, vertical max.	in	0.11
Curve radius, min.	in	0.98

Performance - Lifting forces

F30-2	Vertical (lb)	Parallel (lb)
5.91 -inHg	2.70	2.47
17.72 -inHg	5.62	3.60
26.58 -inHg	6.97	4.50

Material	
Name	Silicone (SIL FDA) 50° Shore
Color	Transparent
Temperature, min. °F	-40.0
Temperature max. °F	392.0
Hardness °Shore A	50

Material resistance

Alcohol	Good
Concentrated acids	Poor
Ethanol	n/a
Hydrolysis	Fair
Methanol	n/a
Oil	Poor
Oxidation	Excellent
Gasoline	Poor
Wear resistance	Good
Weather and ozone	Excellent

Dimensional drawings

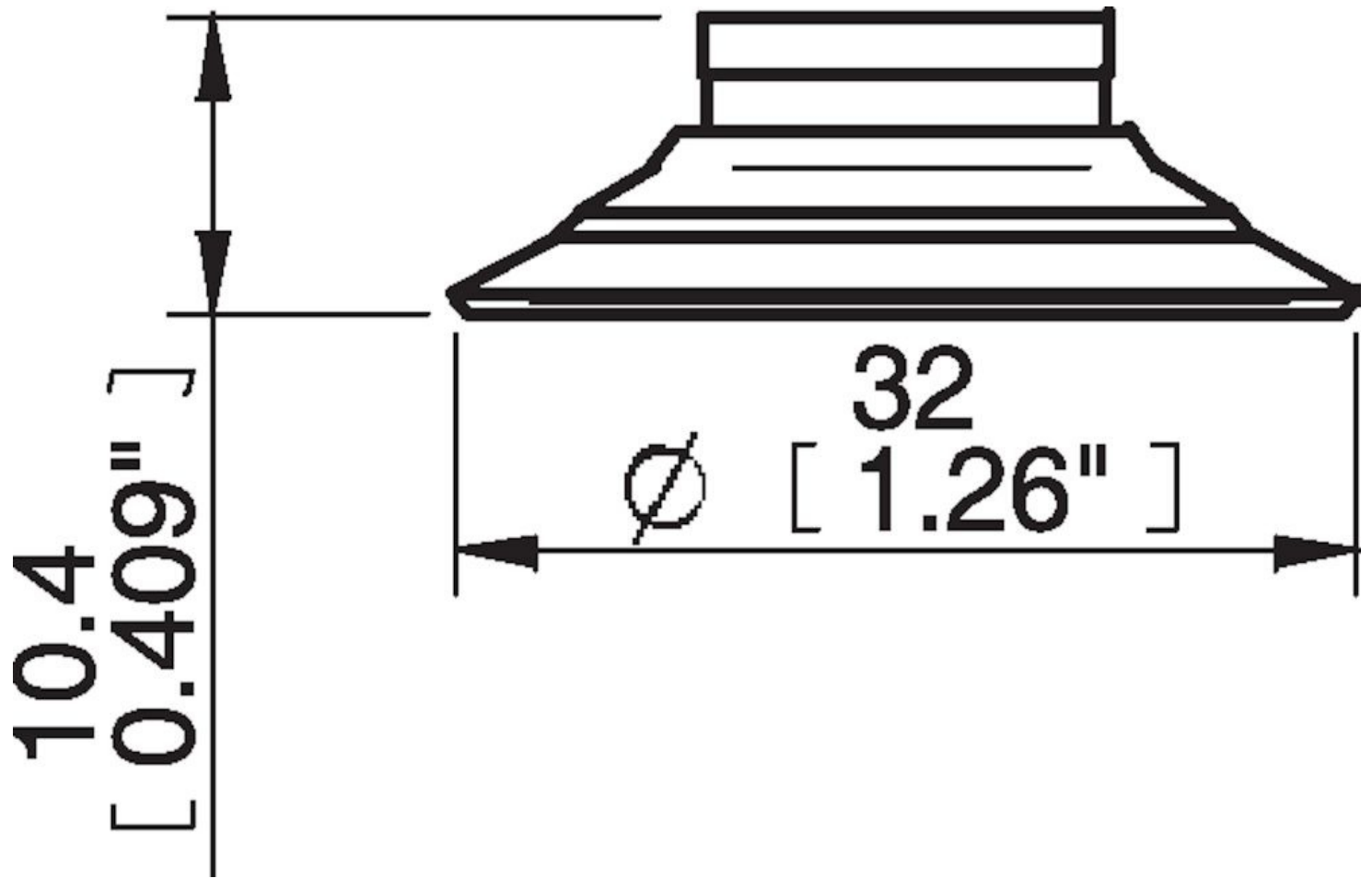

Values specified in this data sheet are tested at (unless otherwise stated):

- Room temperature (20°C [68°F] ± 3°C [5.5°F]).
- Standard atmosphere (101.3 [29.9 inHg] ± 1.0 kPa [0.3 inHg]).
- Relative humidity 20-70%.
- Compressed air quality, DIN ISO 8573-1 class 4.

Accessories

02AF | Fitting G1/8" male/M5 female, with mesh filter

02AB | Fitting G1/8" male, with mesh filter

02AC | Fitting 1/8" NPT male, with mesh filter