

Suction cup B8 Chloroprene, M5 male

Item number: B8.10.01AB

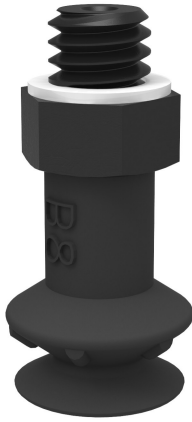

- Lifting movement to separate small and thin objects.
- Only lightweight objects should be handled when the lifting force is parallel to the surface.
- Suitable for level adjustment.
- Suction cups of conductive silicone and semi-conductive EPDM are suitable for objects with sensitivity to static electricity.

Technical data

Description	Unit	Value
Suction cup shape	-	Bellows
Application	-	Dry sheet metal, Electronic / semiconductor, Plastic injection molded parts
Suction cup design	-	Round
Characteristics	-	Dry sheet metal, Electronic / semiconductor, Plastic injection molded parts
Material	-	Chloroprene (CR)
Weight, min.	oz	0.011
Suction cup model	-	B
Volume	in ³	0.0092
Height	in	0.76
Outer diameter, min.	in	0.35
Outer diameter, actuated	in	0.38
Fitting size	-	M5
Fitting option	-	None
Fitting style	-	Male
Fitting type	-	M-thread
Suction cup model	-	B8
Movement, vertical max.	in	0.14
Curve radius, min.	in	0.075

Performance - Lifting forces

B8	Vertical (lb)	Parallel (lb)
5.91 -inHg	0.18	
17.72 -inHg	0.36	
26.58 -inHg	0.56	

Material	
Name	Chloroprene (CR) 50° Shore A
Color	Black
Temperature, min. °F	-40.0
Temperature max. °F	230.0
Hardness °Shore A	50

Material resistance

Alcohol	Good
Concentrated acids	Poor
Ethanol	n/a
Hydrolysis	Good
Methanol	n/a
Oil	Fair
Oxidation	Good
Gasoline	Fair
Wear resistance	Excellent
Weather and ozone	Good

Dimensional drawings

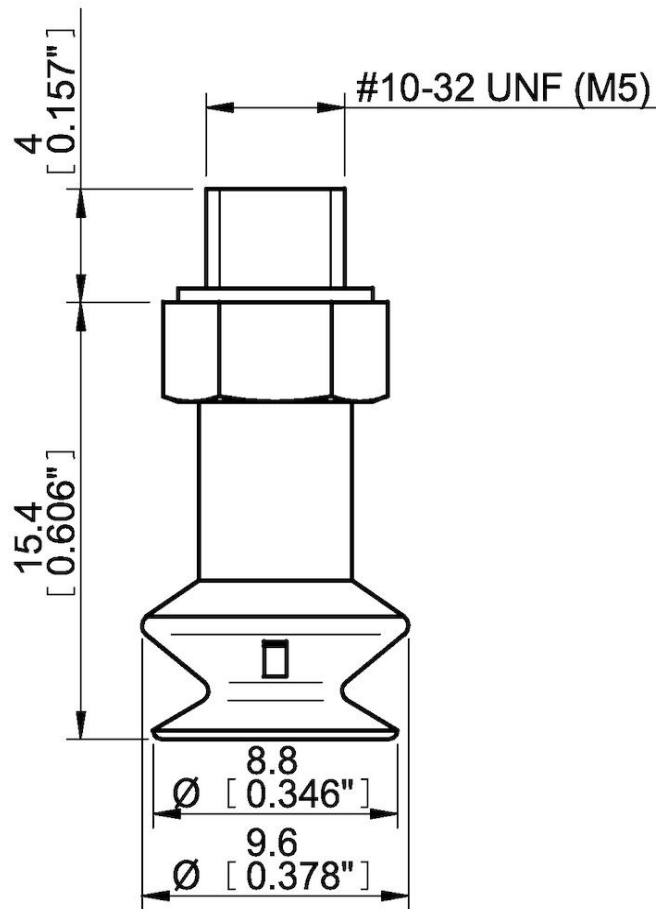

Values specified in this data sheet are tested at (unless otherwise stated):

- Room temperature (20°C [68°F] ± 3°C [5.5°F]).
- Standard atmosphere (101.3 [29.9 inHg] ± 1.0 kPa [0.3 inHg]).
- Relative humidity 20-70%.
- Compressed air quality, DIN ISO 8573-1 class 4.

Accessories

B8.47 | Suction cup B8 HNBR

B8.20 | Suction cup B8 Silicone

B8.25 | Suction cup B8 Conductive silicone

Spare parts

01AB | Fitting M5 male, 5–8

B8.10 | Suction cup B8 Chloroprene