

Datasheet

COAX® cartridge MIDI Pi48-3, extra non-return valve, sealings in Viton®

Item number: 01.24.806



- Three-stage COAX® cartridge - MIDI - with high initial vacuum flow.
- Vacuum level to 27 -inHg at low feed pressure.
- High system reliability in case of fluctuating or low feed pressure.
- Suitable for fast evacuation of large volumes in sealed systems.
- Used in P5010, P6010, P6040 and VGS™5010.

Technical data

Description	Unit	Value
Material	-	Al, FKM, Nitrile (NBR), PA, SS
Temperature, max.	°F	176.0
Temperature, min.	°F	14.0
Weight, max.	oz	2.47
Weight, min.	oz	1.16
Feed pressure, max.	psi	0.10

Performance

Feed pressure psi	Air consumption scfm	Vacuum flow (scfm) at different vacuum levels (-inHg)													Max vacuum psi		
		0	2	5	8	11	14	17	20	23	26	29	32	35			
24.65	2.90	1.18	0.50	0.35	0.21	0.12	0.035	0	0	0	0	0	0	0	0	0	≥7.98
31.90	3.43	1.48	0.59	0.44	0.27	0.16	0.13	0.077	0.021	0	0	0	0	0	0	0	≥10.58
44.95	4.34	1.65	0.74	0.53	0.32	0.19	0.15	0.10	0.074	0	0.030	0	0	0	0	0	≥13.050
58.0	5.38	1.68	0.74	0.62	0.44	0.32	0.19	0.11	0.077	0	0.024	0	0	0	0	0	≥12.47

Feed pressure psi	Air consumption scfm	Evacuation time (s/cf) to reach different vacuum levels (-inHg)													Max vacuum psi		
		2	5	8	11	14	17	20	23	26	28	29	29	29			
24.65	2.90	0.0089	0.030	0.059	0.12	0.30	0	0	0	0	0	0	0	0	0	0	≥7.98
31.90	3.43	0.0074	0.024	0.050	0.089	0.15	0.24	0.50	0	0	0	0	0	0	0	0	≥10.58
44.95	4.34	0.0059	0.018	0.035	0.074	0.13	0.21	0.30	0.47	1.18	0	0	0	0	0	0	≥13.050
58.0	5.38	0.0059	0.016	0.032	0.053	0.086	0.17	0.27	0.50	1.33	0	0	0	0	0	0	≥12.47

Feed pressure psi	Air consumption scfm	Blow flow (scfm) at different pressure levels (-inHg)													Max pressure psi		
		0	2	5	8	11	14	17	20	23	26	29	32	35		38	41
87.0	7.42	1.38	1.16	0.94	0.91	0.87	0.82	0.77	0.68	0.67	0.67	0.67	0.65	0.62	0.58	0.54	≥0

Dimensional drawings

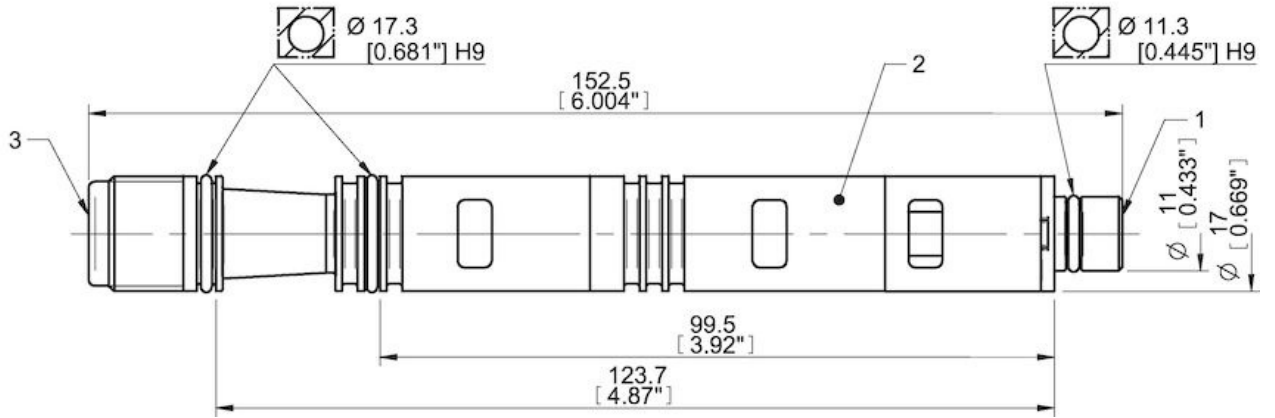
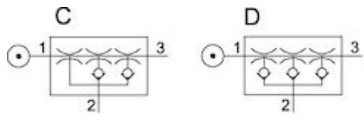

Values specified in this datasheet are tested at (unless otherwise stated):

- Room temperature (20°C [68°F] ± 3°C [5.5°F]).
- Standard atmosphere (101.3 [29.9 inHg] ± 1.0 kPa [0.3 inHg]).
- Compressed air quality, DIN ISO 8573-1 class 4.

Tolerance and accuracy:

- Feed pressure tolerance ±0.02 MPa [2.9 psi]
- Vacuum flow/evacuation time accuracy ±10%.

Accessories

01.11.976 | Silencer COAX® MIDI

Spare parts

01.24.897 | Spare part kit Midi COAX Viton

01.07.131 | Cartridge holder Midi-3 cpl.