

COAX® cartridge MINI Si08-2, extra non-return valve

Item number: 01.13.587



- Two-stage COAX® cartridge - MINI - with small mounting dimensions.
- Large vacuum flow in relation to energy consumption.
- Good for handling porous materials or if surface leakage is present.
- Used in VGS™3010 and VGS™3040.

Technical data

Description	Unit	Value
Material	-	Al, Nitrile (NBR), PA, SS
Temperature, max.	°F	176.0
Temperature, min.	°F	14.0
Weight, max.	oz	0.35
Weight, min.	oz	0.099
Feed pressure, max.	psi	0.10

Performance

Feed pressure psi	Air consumption scfm	Vacuum flow (scfm) at different vacuum levels (-inHg)													Max vacuum psi		
		0	2	5	8	11	14	17	20	23	26	29	32	35			
58.0	0.66	0.21	0.16	0.10	0.077	0.053	0.027	0.0030	0	0	0	0	0	0	0	0	≥8.70
72.5	0.81	0.23	0.18	0.13	0.086	0.068	0.044	0.024	0.0030	0	0	0	0	0	0	0	≥10.15
87.0	0.93	0.23	0.20	0.15	0.097	0.068	0.047	0.035	0.024	0	0	0	0	0	0	0	≥10.88

Feed pressure psi	Air consumption scfm	Evacuation time (s/cf) to reach different vacuum levels (-inHg)													Max vacuum psi		
		2	5	8	11	14	17	20	23	26	28	29	29	29			
58.0	0.66	0.047	0.12	0.21	0.35	0.56	1.15	0	0	0	0	0	0	0	0	0	≥8.70
72.5	0.81	0.041	0.10	0.18	0.30	0.44	0.71	1.36	0	0	0	0	0	0	0	0	≥10.15
87.0	0.93	0.041	0.092	0.16	0.27	0.41	0.62	0.92	0	0	0	0	0	0	0	0	≥10.88

Feed pressure psi	Air consumption scfm	Blow flow (scfm) at different pressure levels (-inHg)													Max pressure psi			
		0	2	5	8	11	14	17	20	23	26	29	32	35		38	41	
87.0	0.93	0.18	0.16	0.14	0.12	0.11	0.11	0.094	0.077	0	0	0	0	0	0	0	0	≥10.88

Dimensional drawings

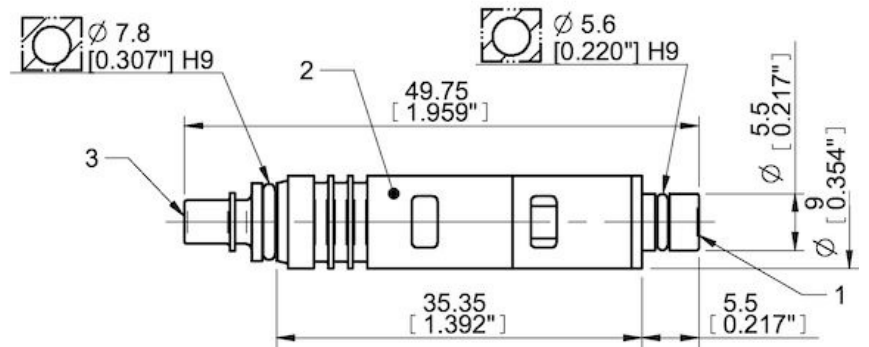
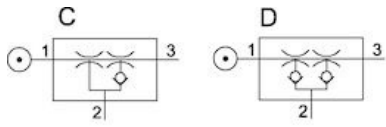

Values specified in this datasheet are tested at (unless otherwise stated):

- Room temperature (20°C [68°F] ± 3°C [5.5°F]).
- Standard atmosphere (101.3 [29.9 inHg] ± 1.0 kPa [0.3 inHg]).
- Compressed air quality, DIN ISO 8573-1 class 4.

Tolerance and accuracy:

- Feed pressure tolerance ±0.02 MPa [2.9 psi]
- Vacuum flow/evacuation time accuracy ±10%.

Accessories

01.06.344 | Exhaust adapter

01.11.977 | Silencer COAX® MINI