

Suction cup FC75P Polyurethane 60, for tread insert

Item number: 01.07.302

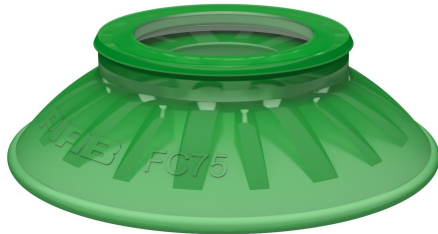

- Suitable for slightly domed and flat and oily surfaces, e.g., such as those encountered when handling steel sheets in press processes.
- Thanks to the high friction of the rubber material, the suction cups can withstand high forces at rapid accelerations in horizontal directions, even on oily surfaces.
- The suction cups have cleats that prevent thin objects from being disfigured.
- DURAFLEX® material features the elasticity of rubber in combination with the wear resistance of polyurethane.
- The DURAFLEX® material is mark-free.

Technical data

Description	Unit	Value
Suction cup shape	-	Flat Concave
Application	-	Dry sheet metal, Mark Free
Suction cup design	-	Round
Characteristics	-	Dry sheet metal, Mark free
Material	-	Polyurethane (PU)
Weight, min.	oz	1.59
Suction cup model	-	FC
Volume	in ³	1.83
Height	in	0.94
Outer diameter, min.	in	2.95
Fitting size	-	None
Fitting option	-	None
Fitting style	-	None
Fitting type	-	None
Suction cup model	-	FC75P PU60
Movement, vertical max.	in	0.32
Curve radius, min.	in	3.071

Performance - Lifting forces

FC75P PU60	Vertical (lb)	Parallel (lb)
5.91 -inHg	16.41	20.91
17.72 -inHg	37.77	50.58
26.58 -inHg	50.58	57.33

Material	
Name	Polyurethane (PU60)
Color	Green transparent
Temperature, min. °F	50.0
Temperature max. °F	122.0
Hardness °Shore A	60

Material resistance

Alcohol	n/a
Concentrated acids	Fair
Ethanol	Fair
Hydrolysis	Fair
Methanol	Poor
Oil	Excellent
Oxidation	Poor
Gasoline	Fair
Wear resistance	Excellent
Weather and ozone	Excellent

Dimensional drawings

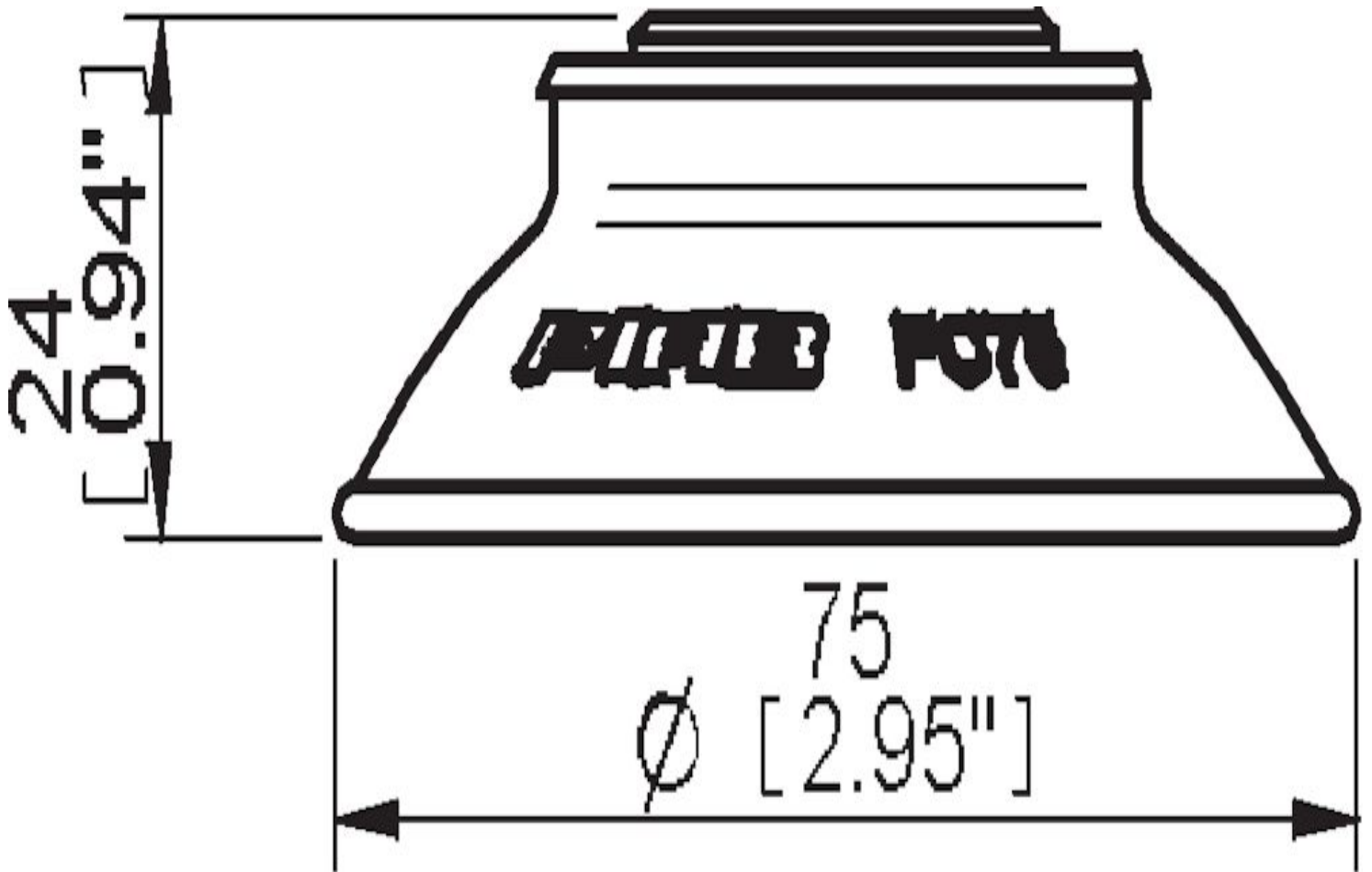

Values specified in this data sheet are tested at (unless otherwise stated):

- Room temperature (20°C [68°F] ± 3°C [5.5°F]).
- Standard atmosphere (101.3 [29.9 inHg] ± 1.0 kPa [0.3 inHg]).
- Relative humidity 20-70%.
- Compressed air quality, DIN ISO 8573-1 class 4.

Accessories

01.07.148 | Thread insert G3/8" male, with O-ring and mesh filter for Vacuum Gripper System (VGS)