

COAX® cartridge MIDI Si32-2, holding cap

Item number: 01.07.126



- Two-stage COAX® cartridge - MIDI - with small mounting dimension for limited spaces.
- Large vacuum flow in relation to energy consumption.
- Suitable for high-volume evacuation when handling porous materials or if surface leakage is present.
- Used in P5010 and VGS™5010.

Technical data

Description	Unit	Value
Material	-	Al, Nitrile (NBR), PA, SS
Temperature, max.	°F	176.0
Temperature, min.	°F	14.0
Weight, max.	oz	2.010
Weight, min.	oz	0.95
Feed pressure, max.	psi	0.10

Performance

Feed pressure psi	Air consumption scfm	Vacuum flow (scfm) at different vacuum levels (-inHg)													Max vacuum psi		
		0	2	5	8	11	14	17	20	23	26	29	32	35			
58.0	2.65	0.92	0.77	0.56	0.35	0.24	0.12	0.030	0	0	0	0	0	0	0	0	≥8.70
72.5	3.18	0.94	0.86	0.65	0.41	0.25	0.18	0.10	0.053	0	0	0	0	0	0	0	≥10.15
87.0	3.71	0.97	0.89	0.77	0.50	0.27	0.18	0.15	0.10	0	0	0	0	0	0	0	≥10.88

Feed pressure psi	Air consumption scfm	Evacuation time (s/cf) to reach different vacuum levels (-inHg)													Max vacuum psi		
		2	5	8	11	14	17	20	23	26	28	29	29	29			
58.0	2.65	0.012	0.024	0.041	0.071	0.12	0.30	0	0	0	0	0	0	0	0	0	≥8.70
72.5	3.18	0.0089	0.021	0.032	0.062	0.10	0.18	0.30	0	0	0	0	0	0	0	0	≥10.15
87.0	3.71	0.0089	0.021	0.030	0.053	0.097	0.16	0.24	0	0	0	0	0	0	0	0	≥10.88

Feed pressure psi	Air consumption scfm	Blow flow (scfm) at different pressure levels (-inHg)													Max pressure psi		
		0	2	5	8	11	14	17	20	23	26	29	32	35		38	41
87.0	3.71	0.73	0.70	0.62	0.52	0.48	0.42	0.38	0.34	0.29	0	0	0	0	0	0	≥10.88

Dimensional drawings

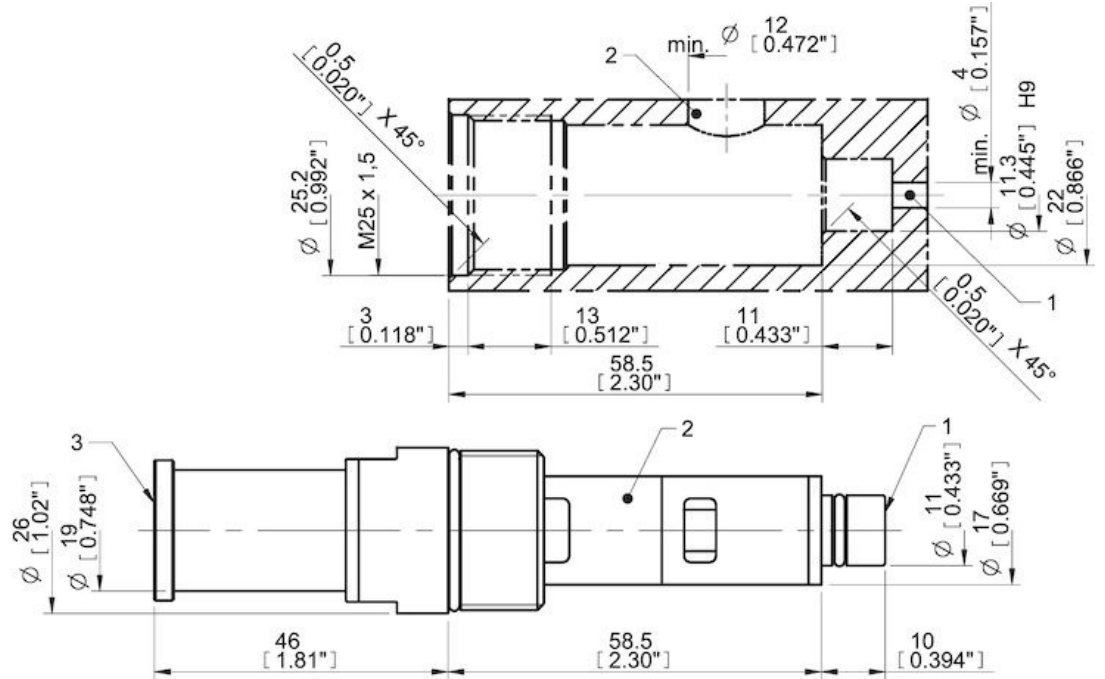
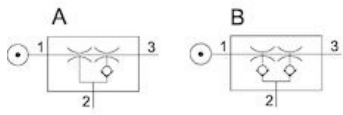

Values specified in this datasheet are tested at (unless otherwise stated):

- Room temperature (20°C [68°F] ± 3°C [5.5°F]).
- Standard atmosphere (101.3 [29.9 inHg] ± 1.0 kPa [0.3 inHg]).
- Compressed air quality, DIN ISO 8573-1 class 4.

Tolerance and accuracy:

- Feed pressure tolerance ±0.02 MPa [2.9 psi]
- Vacuum flow/evacuation time accuracy ±10%.

Accessories

01.11.976 | Silencer COAX® MIDI

Spare parts

- 01.09.531 | Spare part kit Midi COAX
- 01.24.897 | Spare part kit Midi COAX Viton
- 01.07.130 | Cartridge holder Midi-2 cpl.