

COAX® cartridge MINI Pi12-3, holding cap

Item number: 01.06.923



- Three-stage COAX® cartridge - MINI - with high initial vacuum flow.
- Vacuum level to 27 -inHg at low feed pressure.
- High system reliability in case of fluctuating or low feed pressure.
- Suitable for handling sealed objects with high pick-up speed.
- Used in VGS™3010 and VGS™3040.

Technical data

Description	Unit	Value
Material	-	Al, Nitrile (NBR), PA, SS
Temperature, max.	°F	176.0
Temperature, min.	°F	14.0
Weight, max.	oz	0.44
Weight, min.	oz	0.17
Feed pressure, max.	psi	0.10

Performance

Feed pressure psi	Air consumption scfm	Vacuum flow (scfm) at different vacuum levels (-inHg)													Max vacuum psi			
		0	2	5	8	11	14	17	20	23	26	29	32	35				
24.65	0.61	0.27	0.12	0.065	0.044	0.021	0	0	0	0	0	0	0	0	0	0	0	≥7.10
31.90	0.72	0.32	0.14	0.086	0.059	0.041	0.024	0.0059	0	0	0	0	0	0	0	0	0	≥9.28
46.40	0.93	0.41	0.18	0.13	0.080	0.056	0.041	0.030	0.018	0	0.0089	0	0	0	0	0	0	≥13.050
58.0	1.12	0.41	0.21	0.15	0.12	0.071	0.035	0.030	0.018	0	0.0059	0	0	0	0	0	0	≥12.18
87.0	1.67	0.47	0.30	0.15	0.12	0.11	0.083	0.050	0.015	0	0.0030	0	0	0	0	0	0	≥12.035

Feed pressure psi	Air consumption scfm	Evacuation time (s/cf) to reach different vacuum levels (-inHg)													Max vacuum psi				
		2	5	8	11	14	17	20	23	26	28	29	29	29					
24.65	0.61	0.044	0.14	0.30	0.59	0	0	0	0	0	0	0	0	0	0	0	0	0	≥7.10
31.90	0.72	0.030	0.094	0.22	0.41	0.65	0.86	0	0	0	0	0	0	0	0	0	0	0	≥9.28
46.40	0.93	0.024	0.068	0.14	0.30	0.50	0.77	1.15	1.86	0	0	0	0	0	0	0	0	0	≥13.050
58.0	1.12	0.027	0.071	0.13	0.22	0.41	0.71	1.093	2.067	0	0	0	0	0	0	0	0	0	≥12.18
87.0	1.67	0.018	0.050	0.11	0.19	0.30	0.41	0.71	2.66	0	0	0	0	0	0	0	0	0	≥12.035

Feed pressure psi	Air consumption scfm	Blow flow (scfm) at different pressure levels (-inHg)													Max pressure psi				
		0	2	5	8	11	14	17	20	23	26	29	32	35		38	41		
87.0	1.67	0.27	0.24	0.20	0.20	0.19	0.18	0.16	0.15	0.15	0.15	0.15	0.14	0.14	0.12	0.11	0.11	0.11	≥12.035

Dimensional drawings

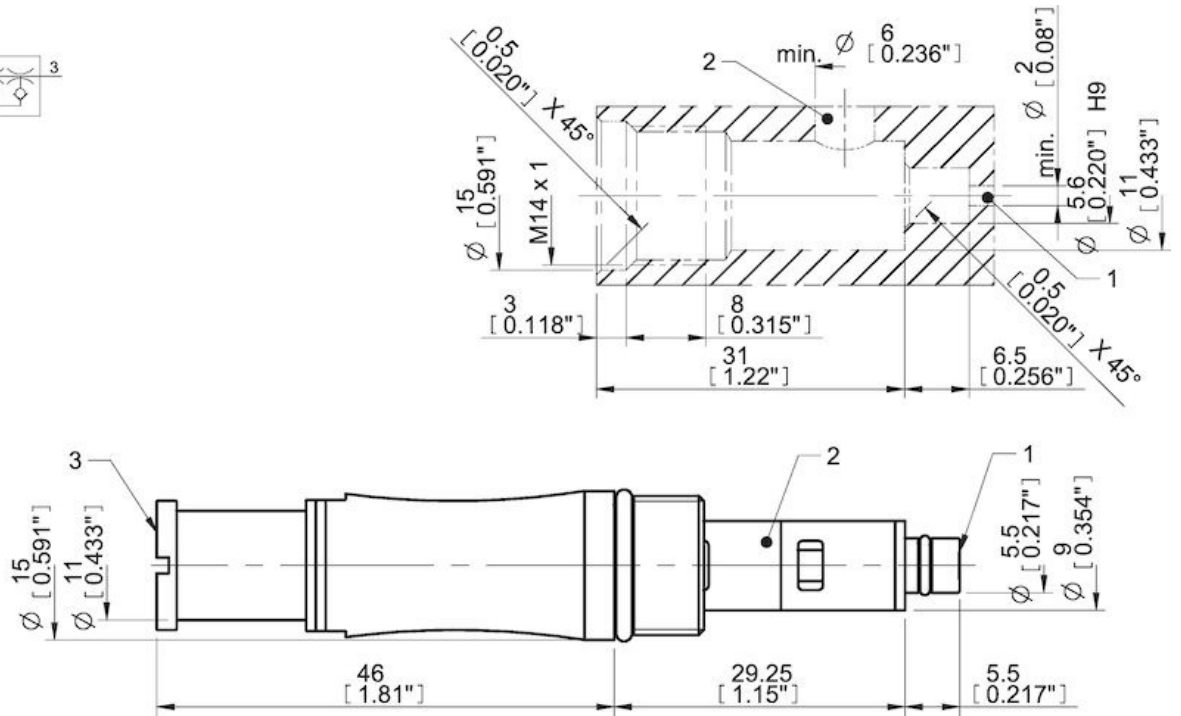
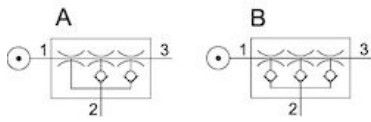

Values specified in this datasheet are tested at (unless otherwise stated):

- Room temperature (20°C [68°F] $\pm 3^\circ\text{C}$ [5.5°F]).
- Standard atmosphere (101.3 [29.9 inHg] ± 1.0 kPa [0.3 inHg]).
- Compressed air quality, DIN ISO 8573-1 class 4.

Tolerance and accuracy:

- Feed pressure tolerance ± 0.02 MPa [2.9 psi]
- Vacuum flow/evacuation time accuracy $\pm 10\%$.

Accessories

- 01.06.344 | Exhaust adapter
- 01.11.977 | Silencer COAX® MINI