

COAX® cartridge MINI Pi12-2

Item number: 01.06.922



- Two-stage COAX® cartridge - MINI - with small mounting dimensions.
- Vacuum level to 27 -inHg at low feed pressures.
- High operational reliability in case of fluctuating or low compressed-air pressure.
- Suitable for handling sealed objects.
- Used in PMAT, VGS™3010 and VGS™3040.

Technical data

Description	Unit	Value
Material	-	Al, Nitrile (NBR), PA, SS
Temperature, max.	°F	176.0
Temperature, min.	°F	14.0
Weight, max.	oz	0.34
Weight, min.	oz	0.092
Feed pressure, max.	psi	0.10

Performance

Feed pressure psi	Air consumption scfm	Vacuum flow (scfm) at different vacuum levels (-inHg)													Max vacuum psi			
		0	2	5	8	11	14	17	20	23	26	29	32	35				
24.65	0.61	0.17	0.12	0.065	0.044	0.021	0	0	0	0	0	0	0	0	0	0	0	≥7.10
31.90	0.72	0.19	0.14	0.086	0.059	0.041	0.024	0.0059	0	0	0	0	0	0	0	0	0	≥9.28
45.53	0.93	0.20	0.18	0.13	0.080	0.056	0.041	0.030	0.018	0	0.0089	0	0	0	0	0	0	≥13.050
58.0	1.12	0.19	0.18	0.15	0.12	0.071	0.035	0.030	0.018	0	0.0059	0	0	0	0	0	0	≥12.18

Feed pressure psi	Air consumption scfm	Evacuation time (s/cf) to reach different vacuum levels (-inHg)													Max vacuum psi			
		2	5	8	11	14	17	20	23	26	28	29	29	29				
24.65	0.61	0.083	0.17	0.33	0.63	0	0	0	0	0	0	0	0	0	0	0	0	≥7.10
31.90	0.72	0.059	0.12	0.25	0.44	0.68	0.89	0	0	0	0	0	0	0	0	0	0	≥9.28
45.53	0.93	0.050	0.094	0.17	0.32	0.53	0.80	1.18	1.89	0	0	0	0	0	0	0	0	≥13.050
58.0	1.12	0.053	0.097	0.16	0.25	0.44	0.74	1.12	2.097	0	0	0	0	0	0	0	0	≥12.18

Feed pressure psi	Air consumption scfm	Blow flow (scfm) at different pressure levels (-inHg)													Max pressure psi			
		0	2	5	8	11	14	17	20	23	26	29	32	35		38	41	
87.0	1.59	0.20	0.20	0.20	0.20	0.19	0.18	0.16	0.15	0.15	0.15	0.15	0.14	0.14	0.12	0.11	0.11	≥0

Dimensional drawings

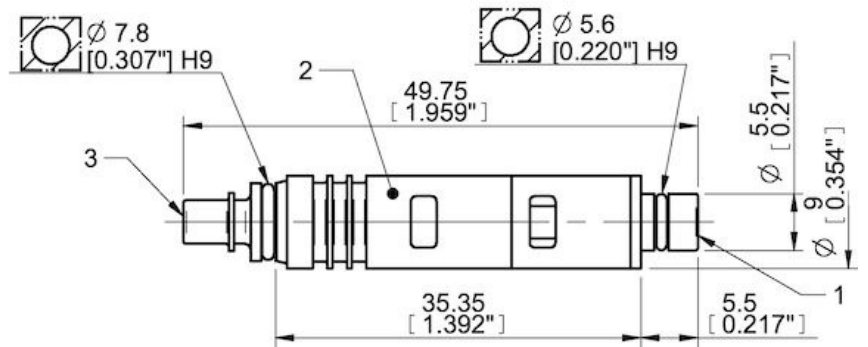
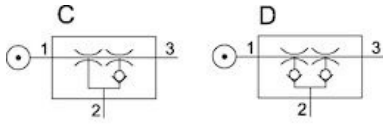

Values specified in this datasheet are tested at (unless otherwise stated):

- Room temperature (20°C [68°F] ± 3°C [5.5°F]).
- Standard atmosphere (101.3 [29.9 inHg] ± 1.0 kPa [0.3 inHg]).
- Compressed air quality, DIN ISO 8573-1 class 4.

Tolerance and accuracy:

- Feed pressure tolerance ±0.02 MPa [2.9 psi]
- Vacuum flow/evacuation time accuracy ±10%.

Accessories

01.11.977 | Silencer COAX® MINI